

MN1000 Optical Receiver

Models MN1000-40-1W-SA and MN1000-44D-1W-SA

User Manual

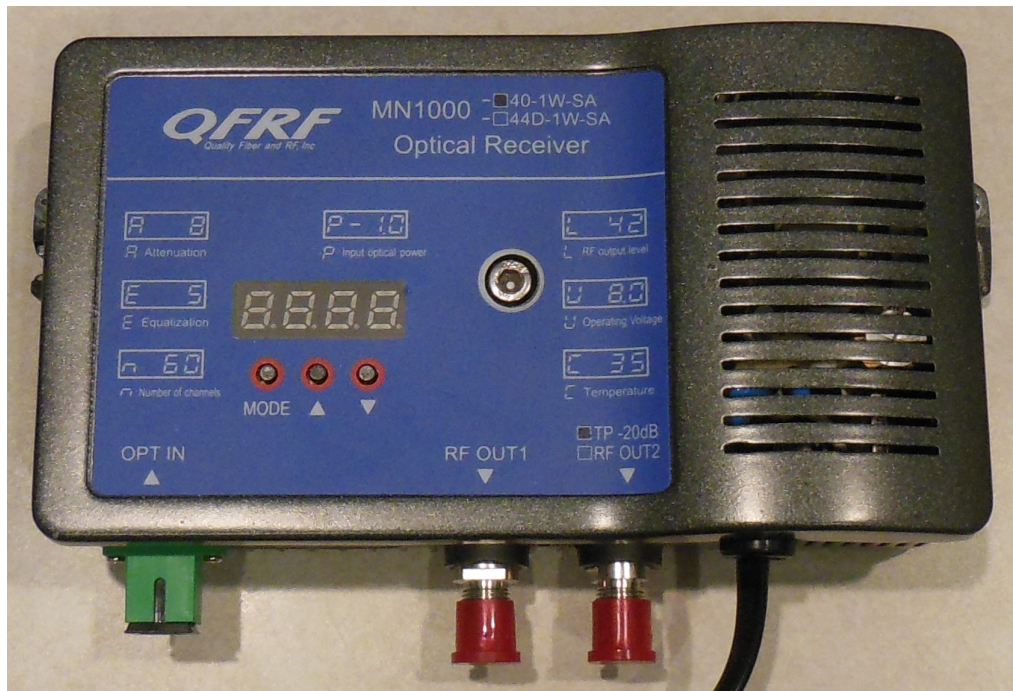

Quality Fiber and RF, Inc.

www.qfrf.com

I. Features

1. FTTB optical receiver with an integrated aluminum die-casting shell.
2. AGC control -7~+2dBm
3. Digital control and display of attenuator, equalizer, and RF output level.
4. Optional remote monitor and control of ATT and EQ value.
5. Optional SNMP management system.
6. Built-in power supply.

II. Structure

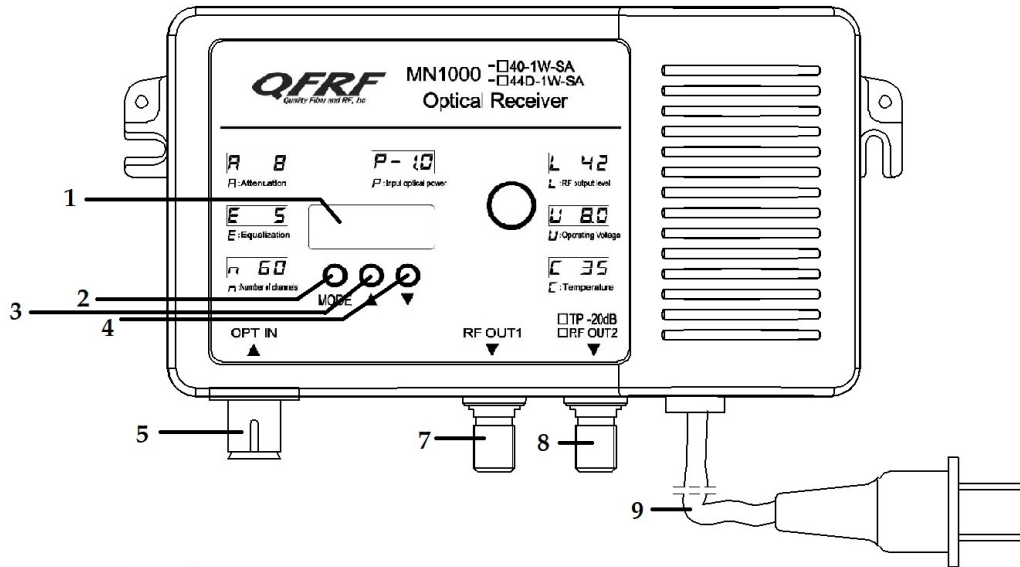

1	Digital display	2	Mode key
3	Up	4	Down
5	Optical Interface	6	NA
7	RF output port 1	8	RF output port 2
9	Power supply		

III. Block Diagram

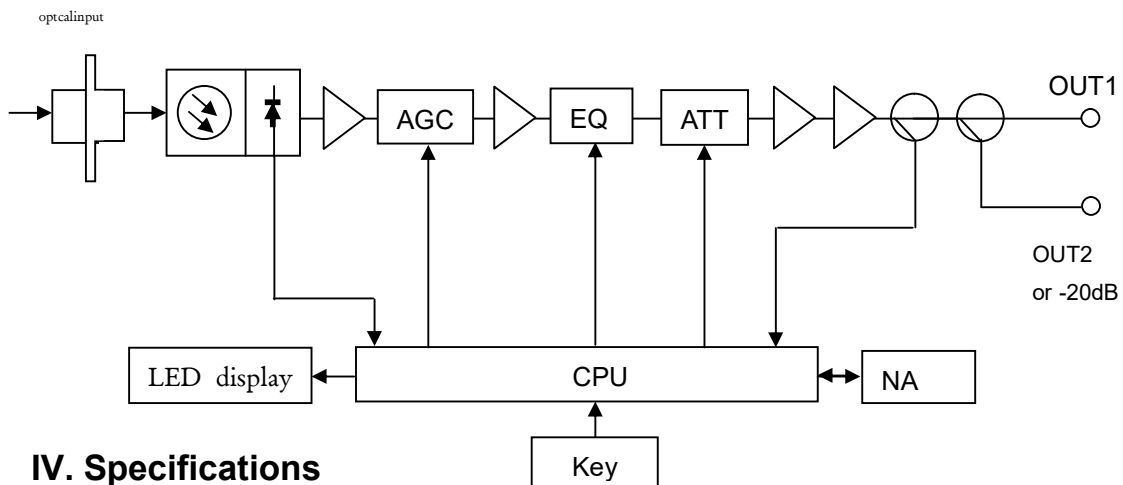

IV. Specifications

No.	Items	Unit	Value	Remarks
			AC/DC	
		AC110~120V	DC+8V/1.5A	

Optical Characteristic				
1	Optical input Range(PIN)	dBm	-8~+3	
2	AGC Range	dBm	-9~+2	
3	Optical Return Loss	dB	>45	
4	Optical Receiving Wavelength	nm	1100~1650	
5	Connector Type		SC/APC	
RF Specifications				
6	Frequency Range	MHz	45~1002	
7	Flatness	dB	±1.0	
8	Return Loss	dB	≥14	
9	ATT Value	dB	0~15	step1dB
10	EQ Value	dB	0~15	step1dB
11	Max.Output Level	dBmV	≥46 (Single output) ≥44 (Dual output)	-7~+2dBm optical power receive
12	Output Impedance	Ω	75	
13	C/N	dB	≥51	
14	C/CTB	dB	≥60	
15	C/CSO	dB	≥60	
Ordinary Characteristic				
16	Power Voltage	V	110~120	
17	Working Temperature	°C	-20~60	
18	Power Consumption	W	≤8.5 (Without SNMP) ≤10 (With SNMP)	
19	Dimension (L×W×H)	mm	191.3×112.5×52.5	

*Testing Conditions: Input power@-1dBm, 128 NTSC channels, OMI=3.5%, RF output level is 46dBmV with 10dB tilt.

V. OPERATION

Press the MODE button until you see the “A” appear in the LED display. Use the UP and DOWN buttons to set the ATTENUATOR value. This affects all the RF channels equally.

Press the MODE button again to display the “E”. Use the UP and DOWN buttons to set the EQUALIZER value. The EQUALIZER pivots at 1 GHz, and determines the dB of tilt on your lowest channels.